

ISSUE: [November 2012](#)

Beyond Power Management: Power Engineers Must Also Solve ESD, EMI, And RFI Problems

by Bill Laumeister, Maxim Integrated Products, San Jose, Calif.

Most of us have seen the label “one size fits all” used for clothing and the signs in a market claiming that the fresh fruit is all equally good. That is rarely true for clothes or fresh food, and it most certainly does not apply to power management in ICs. Radio frequency interference (RFI), electromagnetic interference (EMI), susceptibility (EMS), and electrostatic discharge (ESD)—these are all potential safety hazards that can disrupt an application and even threaten life. Ultimately, each power application has different requirements, its own idiosyncrasies, and its own design traps.

Power engineers are the first line of defense, engineering “super heroes,” or the panacea for managing the disruptive forces of power in all applications. These engineers must be the first to start the project, the consultant to guide other designers, and the last ones in line for improving a system’s energy efficiency.

Knowing that “one size fits all” cannot apply to power design, we focus attention on the 20%/80% rule (see note below) to produce a well-designed power-management circuit. Following this basic principle, the power designer must consider all the potential disruptions to a steady flow of power and then various ways to mitigate them. These disruptions include overvoltage, overcurrent, and interference conditions caused by problems such RFI, EMI, EMS, and ESD. This article, suggests voltage- and current-limiting devices and risetime reducers to manage the power. It also points to free and low-cost software tools to help design lowpass filters, check capacitor self-resonance, and simulate circuits.

The Role Of The Power Engineer

Sometimes power engineers are underappreciated. All circuits need to be powered and corporate management might even think that it is an easy job. We engineers know the real answer, but then we also know the responsibility and expertise expected from an experienced power designer. The days of just buying a really big power supply off the shelf and hoping it works are long gone. Even consumers are conscious of power consumption and vampire (standby current) loads. And as power loads increase, we all worry about safety issues.

Today’s power designer supervises and enforces project design guidelines for power and ground^[1] including wire placement and sizing in the chassis, remote sensing, and power and ground star points in the chassis and on the boards. Board layout is monitored and organized to reduce noise and maintain proper decoupling over the frequency of interest. ESD, EMI, and RFI vulnerabilities are interface issues with the outside world and best handled in a harmonized way. Because power design starts at the outside interface with the input power, the designer is usually tasked to consult with the other designers to protect the other interface points throughout the system.

Understanding this pivotal role, the power designer’s primary focus needs to reflect the 20%/80% rule. In general, many systems are open to similar RFI, EMI, EMS, and ESD issues (the 80% here), but adapting and adding a few special requirements or components (the 20%) provides the protection. (Yes, this is not mysterious or magical art, but it *is* what makes the power engineer a super hero in many companies.)

Where Do You Start?

You need to speed up the project and another engineer suggests: “Buy a filter from a catalog. Put it in front of a stock power supply from a catalog and it should be good enough.” The circuit in Fig. 1 is a typical example of such a filter.

Note: Also known as the Pareto principle and the 80-20 rule, it stipulates that 80% of the results can be attributed to 20% of the causes.

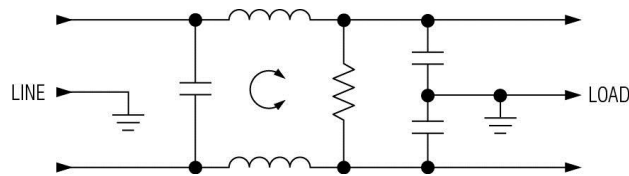

Fig. 1. A common-mode choke powerline filter.

Hmmm, you say to yourself. Is it good enough?^[2] Maybe, but it will be much safer to know for sure. Such is the concern, and systematic approach of an experienced power designer who will test the solution, mathematically and physically.

Consumer and industrial applications are similar when we consider their vulnerabilities. For these seemingly disparate applications, it is crucial that external interference (ESD, EMI, RFI, and EMS) does not jeopardize safety. In a factory we find programmable logic controller (PLC) systems where long wires act as antennas and motor voltages in the hundreds of volts that can short to data wires. The factory or industrial facilities might also be outdoors where weather, lightning, and "ground loops" are prevalent. Consumer devices are always vulnerable to powerline disturbances.

Knowing this, we try to anticipate the majority of ESD, EMI, and RFI vulnerabilities in the application. A simple interface^[3] circuit in Fig. 2 demonstrates the 80% of commonality in a circuit and where to anticipate the 20% of optimized design.

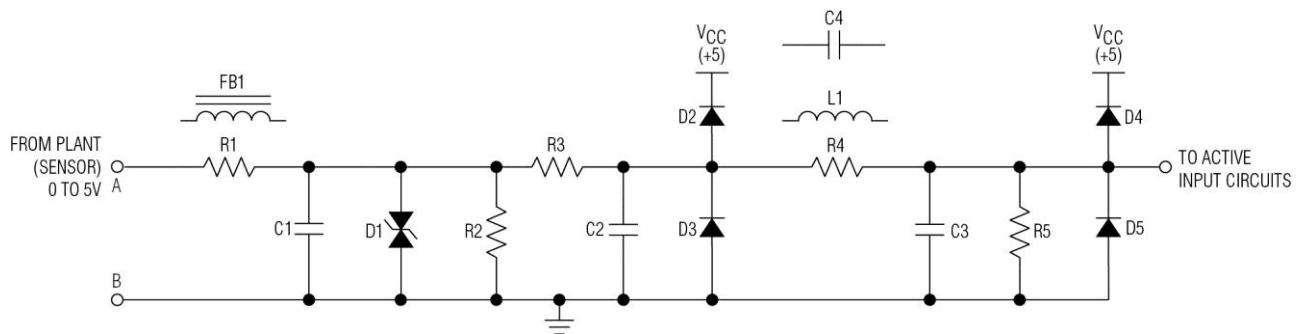

Fig. 2. The 20%/80% interface circuit, which can apply to both input and output points. Substituting one component for a more "generic" device protects against unwanted electrical vulnerabilities.

Looking at Fig. 2, we can group the ESD, EMI, EMS, and RFI devices in three categories;

1. Voltage-limiting devices: gas discharge arrestors, metal oxide varistors, suppressor diodes, triacs, diacs, and switches^[4]
2. Current-limiting devices: fuses, circuit breakers, and thermal cutouts
3. Risetime reducers: resistors, inductors, coils, ferrite beads, and capacitors, all of which slow the risetime of a transient and thereby allow other protection devices time to function.

If we examine the circuit of Fig. 2 carefully, we find:

- R1, R2: precision resistors to attenuate higher input voltages so an ADC with a 3-V range^[5] can be used—the Maxim MAX5490 resistor-divider is suggested for this task.
- R1, C1, D1: resistors that can be replaced with a fuse or ferrite bead, FB1, to limit the current to protect C1-D1 and to form a lowpass filter.
- R2: if this resistor is 250 Ω, it converts a 4- to 20-mA current to 1 V to 5 V for an ADC.
- C1, C2, C3: RFI reduction, anti-alias capacitors
- R3-C2, R4-C3: RC lowpass filters
- D1: a 5.6-V transient voltage suppressor (TVS) diode that clamps -0.6 V to 5.6 V. The Vishay VCUT0505-HD1 is suggested for this task.

- D2-D3: silicon clamp diodes (0.6-V to 0.7-V forward voltage)—the 1N4148 high-speed diode is suggested for low-power transients; larger, silicon clamp diodes—the 1N4001-7 general-purpose rectifiers are suggested for high-power transients.
- D4-D5: Schottky clamp diodes with 0.25-V to 0.3-V forward voltage—BAT54 or SD101 diodes are suggested.
- R1, R3, R4: limits current in the clamp diodes above.
- L1 replaces R4: 2- or 3-pole lowpass filter
- R1, R3, and the wire from the sensor (which could be hundreds or thousands of feet): makes a series R for a filter
- R5: filter output termination
- L1, C2, C3: 2- or 3-pole filters
- C4: AC coupling or parallel to L1 for filter

Capacitors are used with the resistors; ferrite beads and inductors act as lowpass filters. This approach controls the anti-alias filtering for the data converter. It slows the ESD risetime to spread the impulse over time and allows the capacitors to be more effective. The working voltage and self-resonance point of each capacitor needs to match the application's frequency and bandwidth.

Each of these networks is reciprocal; they protect a system from the outside world and protect the outside world from any unintentional signal that a device might radiate. The software tools^[6, 7] work with Fig. 2 to create and simulate the eventual circuit.

Conclusion

Obviously this short article provided only an introduction to the range of ESD, EMI, RFI, and EMS protection that the power-design engineer has available *and* needs to consider. We should all be thinking about the 20%/80% rule in a design and about the potential dangers to guard against in our real-world applications. This sensitivity to the issues with power management is why the experienced power engineer is the unsung hero in a design project.

Finally, we did not talk about energy efficiency in this article. It will be the topic of a future article.

References

1. Maxim Integrated application note 4345, "Well Grounded, Digital Is Analog," at www.maximintegrated.com/AN4345.
2. Maxim Integrated tutorial 5065, "Radio Susceptibility—Cure with Antibiotic, Vaccine, or the Laws of Physics?" at www.maximintegrated.com/AN5065.
3. Maxim Integrated application note 1833, "Using RS-485/RS-422 Transceivers in Fieldbus Networks," at www.maximintegrated.com/AN1833.
4. Maxim Integrated application note 1167, "Practical Aspects of EMI Protection," at www.maximintegrated.com/AN1167. This note discusses power isolation with transformers, circuit protection devices from a gas arrester to resistors, fault-protected, high-voltage, signal-line protectors like the MAX4506 and MAX4507, and EMI immunity testing and measuring techniques.
5. Maxim Integrated application note 2398, "3V DACs Used in $\pm 10V$ Applications," at www.maximintegrated.com/AN2398.
6. At www.maximintegrated.com/cal see links to Maxim tools and calculators. Provided there are more than six analog design calculators for HP50g and a free PC emulator; an online design and simulation of programmable filters.
7. At www.maximintegrated.com/cal also see links to:
 - a. Micro-Cap 10 circuit simulator from Spectrum Software (free evaluation version)
 - b. Solve Elec is a simple circuit simulator (donation software)
 - c. FilterFree is a filter design program for filters up to three poles. (freeware)
 - d. Kemet Spice Software (freeware)
 - e. Johanson Technology, JTIsoft (freeware) is comprised of two advanced design simulation software packages, MLCsoft and MLIsoft. This software provides complete S-parameter and SPICE modeling data on Johanson's line of RF multilayer ceramic capacitors and inductors over the frequency range of 1 MHz to 20 GHz.

- f. AADE Filter Design and Analysis (freeware)

About The Author



Bill Laumeister is an engineer in strategic applications with the Precision Control Group at Maxim Integrated Products. He works with customers who use DACs, digital potentiometers, and voltage references. He has more than 30 years of experience and holds several patents.

For further reading on the topics of ESD, EMI, and RFI, see the [How2Power Design Guide](#), select the Advanced Search option, go to Search by Design Guide Category, and select "EMI and EMC" and "Power Protection" in the Design Area category. Also select "Circuit Protection Devices" in the Component category.