

ISSUE: [March 2017](#)

The Origin And Development Of The High-Efficiency Class-E RF Power Amplifier

On November 15, 2011, the Polytechnic University of Madrid bestowed an honorary doctorate on Nathan O. Sokal. In anticipation of this honor, he prepared the following talk describing how he and his son Alan developed the Class E amplifier.

First, I would like to thank all those at the University who were instrumental in conferring this honor on me. And I would like to thank my friends and family who are joining in the celebration. It feels very special at this point in my career to receive the designation of "Doctor Sokal." There are many Doctor Sokals in my family, including four generations of PhD scientists, researchers and medical doctors.

Although I considered entering a doctoral program relatively early in my career, I had a good job and a good marriage, and I decided against returning to the life of a student. I have enjoyed my job and my marriage over these sixty years, and it is truly an honor to be recognized with a doctoral degree without needing to be a student again!

Today I will tell you about the origin and development of the High-Efficiency Class-E RF Power Amplifier. But first I'd like to mention a few changes I have seen as an electronics engineer during the past 60 years.

My undergraduate and graduate work was at the Massachusetts Institute of Technology in the years immediately following World War II. My entering class in 1945 consisted of 600 students, 6 of whom (1%) were women—now, 40% of incoming students are women. The department back then was called "Electrical Engineering"—now, it is called "Electrical Engineering and Computer Science," with the majority of students being in "Computer Science."

Vacuum tubes were the active devices used then, and designs were made on the 3 x 6-inch graphs in the RCA handbook. RCA was then a major electronics company—now, it no longer exists. Everything was done with paper and pencil, or with slide-rules such as the popular "log-log duplex decitrig" —nowadays you will probably see slide rules only in museums. You young folks will see more changes in the field, at an increasing rate.

Now to the topic I chose to discuss—the origin and development of the high-efficiency Class-E RF power amplifier. It all started in 1969 on a family trip to California to visit my sister, my brother-in-law and their children. My brother-in-law (Robert Booth) was an experienced electronics engineer. He was very enthusiastic about the new hobby that he and several of his children were taking up—becoming "ham" amateur radio operators. He showed us his equipment and the procedure needed to become a ham-radio operator, and he demonstrated how one goes about making the radio connection with another ham-radio operator.

He explained the equipment we would need to buy, learning the Morse code, and then how and where to take the test to become licensed ham-radio operators. It's interesting that one first had to become proficient in the use of the Morse code, and only later could one qualify to use his voice and speak by audio modulation of his carrier signal. However, the Morse-code requirement was abolished in many countries between 2003 and 2007.

Ham radio sounded appealing as a hobby for my son Alan (then 14 years old) and me to do together. From an early age, Alan was interested in things scientific. We followed my brother-in-law's advice, made the purchases, set up an outdoor antenna, studied the Morse code, and finally took and passed the test to become licensed ham-radio operators. We even posted a huge map of the world and had colored pins to put in the places where we had made radio contacts. Alan was in high school, and the school had a Ham Radio Club. There was a yearly field trip where the club members would spend the night outdoors with radio equipment and see how many contacts they could make in a given time.

Alan had trouble with his signal (60 watts) being drowned-out by very powerful transmitters operating near his frequency. At that time, the ham-radio regulations allowed the radio transmitter to be fed up to 1 kilowatt (kW) of dc input power. The very strong signals that were drowning-out Alan's transmissions were colloquially referred to as "Texas Kilowatts," because many hams suspected that those very strong signals were coming from transmitters that were fed by much more than the legal limit of 1 kWdc. At that time, Texas prided itself

on being bigger and better in everything. Alan wanted to use a transmitter that would output as much RF power as possible, when being fed the legal limit of 1 kW dc-input power.

So Alan and I started to think about the issue of efficiency for radio-frequency power amplifiers, motivated by the fact that United States ham-radio regulations limited the *dc input* power to the final amplifier stage as 1 kW. Therefore, the more efficient we could make the amplifier, the more output power we could get legally. It's amusing that our initial motivation was recreational, not commercial; mobile phones were still more than 10 years in the future.

We knew that the RF output power would be the dc input power minus the dissipated power. So we knew we should minimize the power dissipation. We thought about the voltage and current waveforms of an RF power amplifier and about what caused the power dissipation. The next step would be to minimize this dissipation. We already knew about Class-D switching-mode amplifiers, so we tried to find waveforms that would improve on what was found in Class D. We decided on the proper waveforms for minimizing power dissipation, and we then designed a circuit to give that performance. It ended up being a new set of circuit values, and circuit topology different from many conventional circuits.

In April of 1973, we filed a patent application for the low-dissipation circuit. We called the amplifier "Class E"—the next letter after the already designated Class A, Class B, Class C, and Class D. My brother-in-law, who had started us in ham-radio, told me that our "Class-E" patent application was the best technical document he had ever seen. He said that the "E" in the circuit name was really for "Excellent."

At that point, Alan was a college student at Harvard University. Alan remembers doing research over a Christmas vacation in the Harvard Law Library to try to answer some of the patent examiner's legal objections to the way we had phrased our claims. Alan did the research citing all the legal precedents to support our case and we finally gave it to our patent attorney who had his secretary type it up. (Do you remember the Dark Ages when secretaries did the typing on manual typewriters with carbon copies?) The legal arguments were evidently convincing, because the patent was granted in November of 1975, with all of our patent claims being allowed.

While Alan was still an undergraduate at Harvard, we wrote a technical article for the IEEE Journal of Solid-State Circuits. We submitted the article on January 23, 1974 (the day before Alan's 19th birthday), revised it a year later, and finally saw the published article in June 1975. The article says that "A preliminary version of this paper was presented at the 1972 IEEE International Symposium on Circuit Theory in Los Angeles, California in April 1972"—so the main ideas must have been in place by late 1971 when Alan was still in high school.

Later, when Alan was a graduate student at Princeton University, he did some further mathematical derivations and wrote a computer program to compute exactly some of the things that we had previously done by a high-Q approximation. Another bit of antiquity: Alan entered the computer program code on a stack of punched cards! I suggested that he draw a diagonal line with a "magic marker" ink-pen over the stack of punched cards, so that, if he would accidentally drop the stack of cards and the cards got jumbled, he could easily restore the proper order. Luckily, that safety measure was never needed. By that time, Alan was busy with his PhD research. I took up the further development of Class E, resulting in RF power amplifiers of about 90% efficiency instead of about 50% or less.

During the next few years, I presented technical papers about details of Class-E amplifiers at conferences and published them in technical journals. Slowly, engineers began to understand the advantages of using Class-E circuits for RF power amplifiers.

I also began applying Class-E ideas to high-efficiency dc-dc conversion, publishing additional papers in that subject. It took several years, but eventually Class-E circuits were being used in more and more applications—RF power generation and dc-dc power conversion.

Let me briefly give you a more technical explanation of Class-E. Fig. 1 illustrates a circuit diagram of the High-Efficiency Class-E RF Power Amplifier in its basic circuit topology. The circuit converts dc (direct current) power to RF (radio frequency) power, at high efficiency. The dc power is obtained from a battery, or by converting ac power from the electrical mains to dc in a standard "rectifier" circuit. This dc power is fed into the Class E circuit via the inductor L1. The "Active Device Switch" (which is usually some sort of transistor) is switched periodically

“on” and “off” at the chosen radio frequency. This generates ac power at that radio frequency, which is then fed via the “Load Network” to the “Load”. The “Load” is the desired end user of the RF power—for instance, a radio antenna—and its electrical value R is determined by the task to be performed. The circuit components $C1$, $C2$, and $L2$ are chosen to have electrical values that will result in the special voltage and current waveforms shown in Fig. 2.

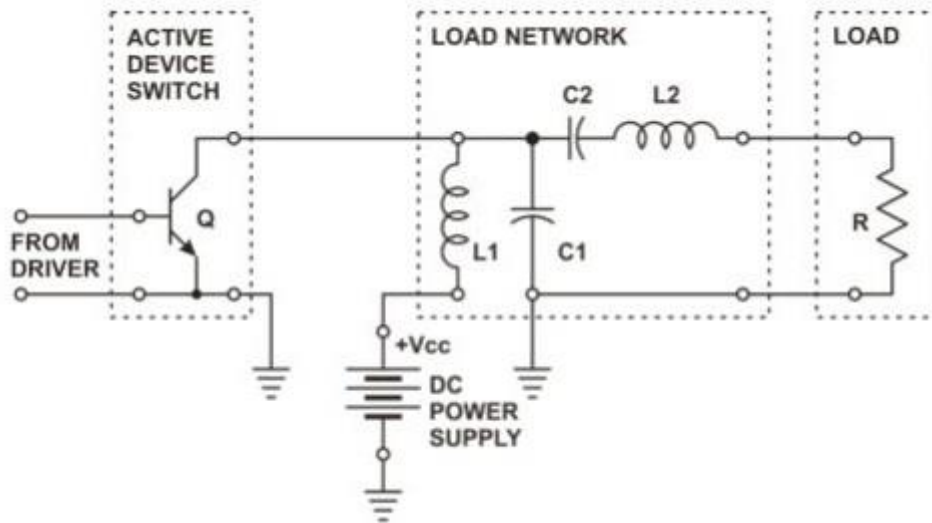

Fig. 1. High efficiency Class E RF power amplifier.

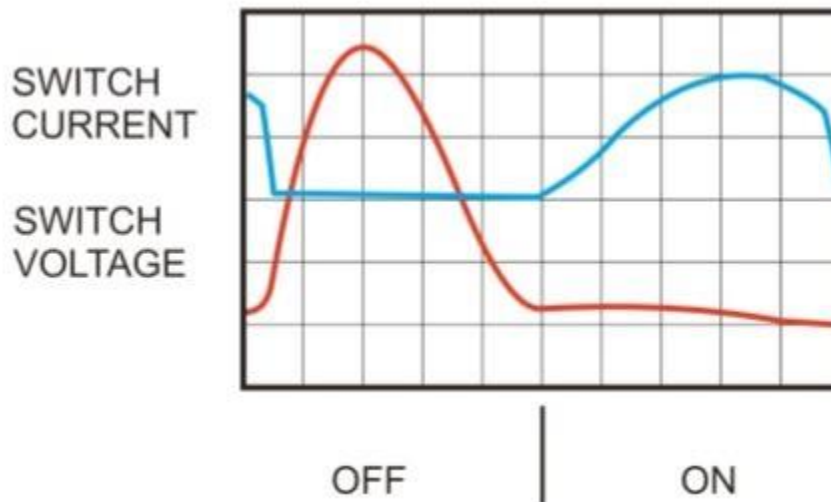

Fig. 2. Voltage and current waveforms for high efficiency.

What is so advantageous about those waveforms? The main point is that they have nearly zero voltage whenever the current is non-zero, and they have nearly zero current whenever the voltage is non-zero. Hence non-zero voltage and non-zero current essentially do NOT exist at the same time, which means that almost zero power is dissipated in the Active Device Switch. Observe also that the voltage returns to zero, with zero slope, precisely at the moment that the switch is to be turned back on; in this way we minimize the dissipation of energy when capacitor $C1$ is discharged through the switch (a problem that was very serious in Class D, where the voltage waveform was a square wave).

The result of all this is that substantial RF power is delivered to the load, with almost zero power being dissipated in the Class-E amplifier itself. That is HIGH EFFICIENCY.

Other types of amplifiers (for example, Classes A and B) have transistor voltage and current at the same time, resulting in substantial power dissipation and low efficiency, of the order of 50% or less. The Class-E amplifier has efficiency of the order of 90%. If a Class-E amplifier with 90% efficiency is used to replace a different type of amplifier that has only 50% efficiency, then the same output power can be obtained with about HALF as much input power (56% to be precise). That is a substantial saving of electrical power!

In addition, Class-E can cope with component parasitic parameters inherent in solid-state technology, such as transistor intrinsic capacitances and non-zero switching times. These advantages make Class-E efficiency higher than is available with many other types of amplifiers.

Even though Class-E technology was developed forty years ago, it is still being used by both researchers and electronics industry, worldwide. A student at La Universidad Politecnica de Madrid counted 94 publications about Class-E in IEEE journals and technical conferences in the year 2010. Class-E has a long life!

One of the officers of the IEEE Journal of Solid-State Circuits told me in 2007 that, of all the papers published in that journal during the years 1975 through 1980, the Sokals' Class-E paper of 1975 was one of the top two most-requested article reprints. (Of course, nowadays, with on-line access to journals via the Internet, no one requests hard-copy reprints anymore!)

Industrial applications for high-efficiency Class-E RF power amplifiers include the following:

- Sending audio or television signals from a Class-E radio transmitter to a receiver many kilometers away.
- Sending communications between a Class-E radio transmitter on an orbiting satellite and the communications facility in the earth-station.
- Generating heat for a chemical or physical reaction, in an industrial process.
- Generating gentle heat inside a human body for medical treatment, such as warming tissue for physical therapy.
- Providing heat to gently warm up blood in the veins of the hands to increase manual dexterity, for example, in the hands of an underwater naval worker in the cold ocean.
- Supplying RF power to ionize a gas in a glass chamber for a chemical reaction, from a Class-E amplifier outside the chamber.

Once Class E was acceptable as "real" to most engineers, my company developed software for designing and optimizing Class-E amplifiers. I specified what the software should do, and how it should do it, and my company's software engineer developed the executable code. The software was sold to engineers who were developing Class-E amplifiers. The software was well received and it was timed as nine times as fast as a "standard" software from one of the major commercial vendors.

Back to my original story. . . An interesting fact is that in 1987—nearly two decades after my son and I had started our ham-radio hobby—the United States ham-radio regulations were changed, and now the legal limit on transmitter power is 1.5 kW OUTPUT. Thus, our original motivation of improving signal strength with limited input power had disappeared! Nowadays the only incentive for efficiency is to avoid wasting power.

So you see, big ideas can come from unlikely sources. Class E started with a suggestion from my brother-in-law of a hobby to share. There was an imposed limit on input power that was frustrating our success with this hobby. Then father and son worked together to try to improve our equipment to overcome this limit, and later patented and found commercial applications for these ideas. And now many researchers like yourselves are using and improving on these ideas.

So one thing that really has not changed very much in my sixty years in electronics is the origin of good ideas. Good ideas are born from external challenges, people working together, developing a response to one problem into broader applications, and a little bit of being in the right place at the right time. I hope that you all have long and fulfilling careers and will further the work in your field through fruitful collaborations, as I have had the opportunity. Thank you again; I am truly honored by this recognition.