

Digital Power Controller Supports Flexible Bus Converter Design Up To 800 VDC

[Infineon Technologies'](#) XDPP1188-200C digital power controller IC is designed to meet the requirements of modern AI server power architectures. It supports intermediate bus conversions from 48 V to 12 V or lower, as well as future higher-voltage dc systems, including the conversion of $\pm 400\text{-V}$ or 800-Vdc bus voltage to 48 V, 24 V, or 12 V (see the figure).

The XDPP1188-200C complements Infineon's CoolGaN-based HV IBC reference designs and offers customers who want to develop their own controller-based solutions maximum flexibility for 800-Vdc or 48-Vdc architectures. While the reference designs enable fast entry with validated solutions, the XDPP1188-200C allows optimization for customer-specific requirements. In 48-V systems, the controller works seamlessly with MV IBC modules to realize an optimized power supply chain from the intermediate bus to processor voltage regulation.

According to the vendor, the XDPP1188-200C features an advanced feed-forward control mechanism that significantly improves response time and stability under dynamic input transient conditions. To handle the rapid power demand fluctuations typical of AI servers, the controller provides a non-linear fast transient response, maintaining accurate and stable voltage regulation during sudden load changes.

The controller's additional ADC inputs enable interleaved topologies to support higher power demands. In addition, the device integrates advanced power management techniques at light-load conditions, optimizing energy efficiency through phase shedding and burst operation. This enables high efficiency across a wide load range.

The XDPP1188-200C supports bidirectional configuration, enabling flexible power management and allowing energy to be directed efficiently where it is most needed within the system. The XDP digital power controller IC family is optimized for use with Infineon's broad AI server power delivery portfolio from grid to core—spanning solid-state transformers and circuit breakers, high-voltage and intermediate bus conversion, as well as second-stage dc conversion power modules.

The XDPP1188-200C controller is now sampling. For more information, see the XDPP1188-200C product [page](#).

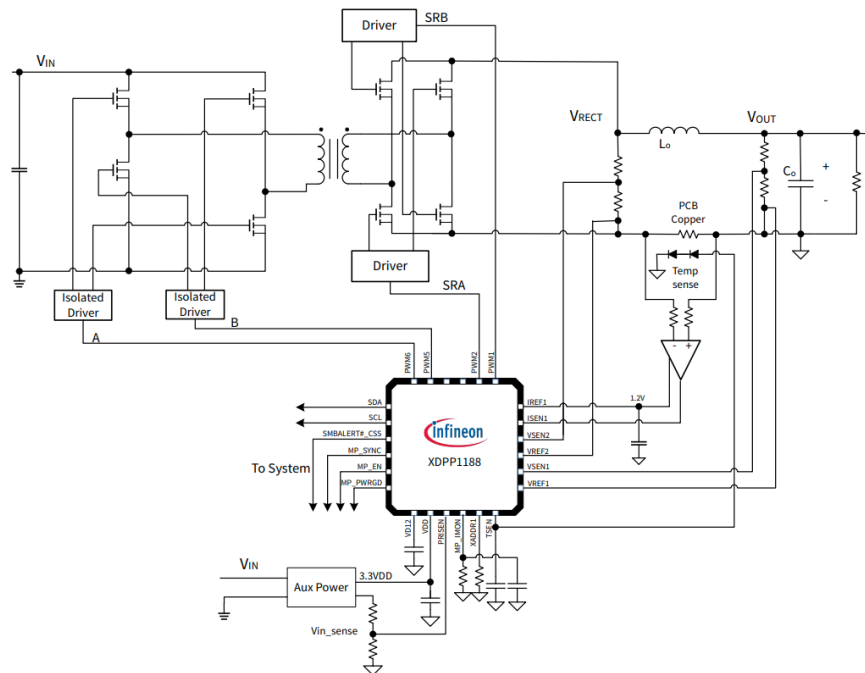

Figure. The XDPP1188 is a digital power supply controller for ac-dc and dc-dc power converters. The controller has a high-performance analog front end, a unique architecture with optimized power-processing digital blocks, and built-in ready to use firmware that minimizes firmware development effort. The state-machine-based configurable control loop architecture supports various modes of operation including PWM and PFM modulation, and voltage mode and peak current mode control. An application circuit is shown here.