

Isolated Power Modules Enable Higher Power Density In Data Centers And EVs

[Texas Instruments'](#) UCC34141-Q1 and UCC33420 isolated power modules enable increased power density, efficiency and safety in applications ranging from data centers to electric vehicles (EVs). The modules leverage TI's IsoShield technology, a proprietary multichip packaging solution that achieves up to three times higher power density than discrete solutions in isolated power designs, according to the vendor.

TI's IsoShield technology copackages a high-performance planar transformer and an isolated power stage, offering functional, basic and reinforced isolation capabilities. It enables a distributed power architecture, helping manufacturers meet functional safety requirements by avoiding single-point failures. The result is a packaging advancement that shrinks solution size by as much as 70% while delivering up to 2 W of power, enabling compact, high-performance and reliable designs for automotive, industrial and data center applications that require reinforced isolation, says the vendor.

The UCC34141-Q1 is an automotive-qualified, dc-dc power module with 5.5-V-to-20-V input and is designed to provide 1.5-W power to SiC and IGBT isolated gate drivers. It measures 5.85 mm x 7.5 mm x 2.6 mm (Fig. 1). The UCC33420 is an industrial dc-dc power module with 4.5-V to 5.5-V input and regulated 5.0-V, 1.5-W output. This device measures 4 mm x 5 mm x 1 mm (Fig. 2).

Preproduction and production quantities of the isolated power modules are available now on TI.com. Evaluation modules, reference designs and simulation models are also available. For more information, see the [UCC34141-Q1](#) and [UCC33420](#) product pages..

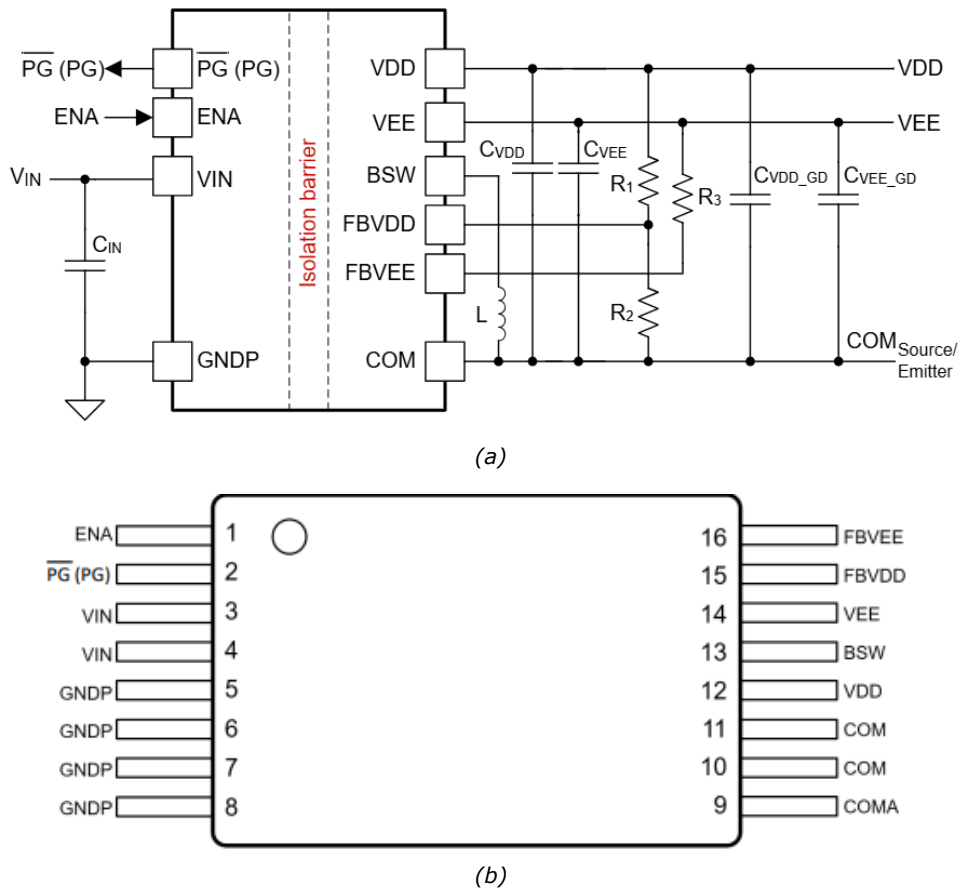

Fig. 1. The UCC34141-Q1 is an automotive, 5.5-V-to-20-V input, 1.5-W regulated 5-kVrms isolated dc-dc module with integrated transformer. It is designed to provide power to SiC and IGBT isolated gate drivers. An application diagram is shown in (a) and a package diagram is shown in (b).

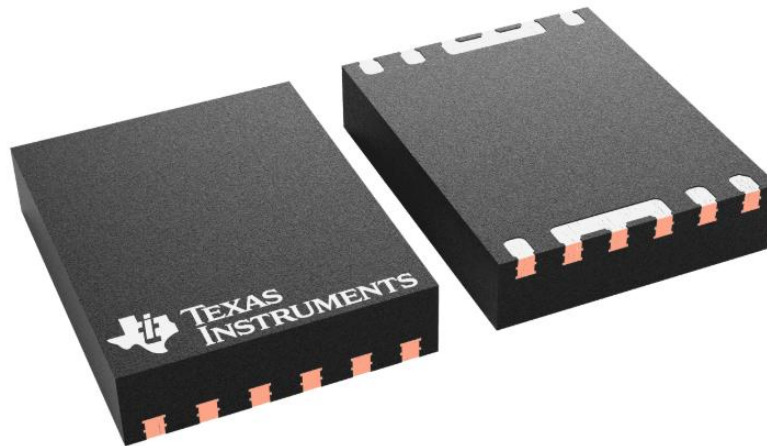
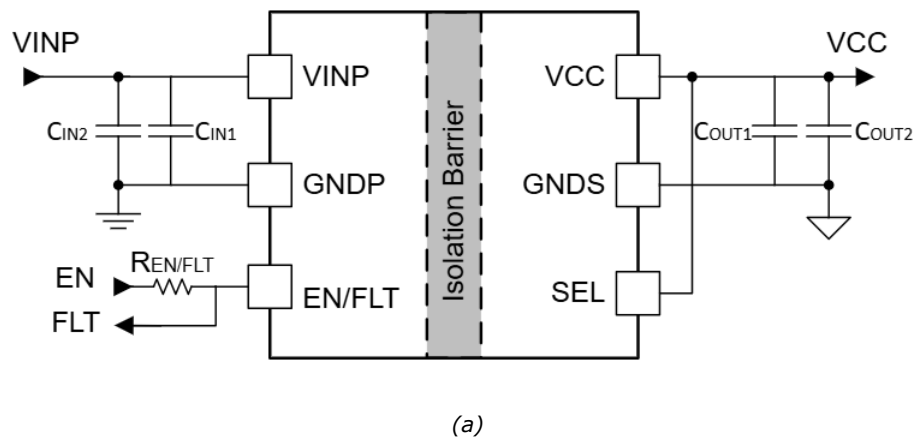

Fig. 2. The UCC33420 is a 5-V/5-V 1.5-W 3-kVrms isolated dc-dc module with integrated transformer. It can support an input voltage operation range of 4.5 V to 5.5 V and regulate 5.0 V output voltage with a selectable headroom of 5.5 V. An application diagram is shown in (a) and a drawing of its 12-pin (RAQ) package is shown in (b).